

Lifting Scheme Optimal Adaptive Wavelet Transforms without Using Extra Additional Information

Wang Jian

Department of Electronic and Information Engineering, The Hong Kong Polytechnic University, M1504,
Li Ka Shing Tower, Hung Hom, Kowloon, Hong Kong

E-mail: wangjian@yahoo.com.hk

Abstract

Wavelet transforms via lifting scheme provides a general and an adaptive flexible tool for the construction of wavelet decompositions and perfect reconstruction filter banks. According to the construction of the lifting wavelet transforms, the optimal filter design method for the adaptive update wavelet transform is proposed by the authors. The optimal update filter coefficients can be acquired based on the Minimum Mean Square Error Criteria (MMSE) in the algorithm. In prediction process, take the case of LeGall 5/3 wavelet; we propose an adaptive version of this scheme that it allows perfect reconstruction without any overhead cost for the smooth signals with the jumps. Compare with other wavelet transform scheme, simulation results show that the adaptive wavelet transform proposed by this paper can achieve the detail signals being zero (or almost zero) at big probability and the better linear approximation for the piecewise continuous signals.

Keywords: Lifting scheme, adaptive wavelet transform, optimal Update filter, MMSE.

1. Introduction

Because of the better temporal and frequency properties, discrete wavelet transforms (DWT) have wide application in signal and image processing [1, 2]. It is well known that wavelet linear approximation (i.e. truncating the high frequencies) can approximate smooth functions very efficiently: it can achieve arbitrary high accuracy by selecting appropriate wavelet basis, it can concentrate the large wavelet coefficients in the low frequencies, and it has a multiresolution framework and associated fast transform algorithms. Standard wavelet linear approximation techniques cannot achieve similar results for functions which are not smooth. The jumps generate large high frequency wavelet coefficients and thus linear approximation cannot get the same high accuracy near the points of discontinuity as in the smooth regions. In fact, the jump points generate oscillations which cannot be removed by mesh refinement.

To overcome these problems within the standard wavelet transform framework, an adaptive ENO-wavelet transform has been presented in [3], which do not generate large high frequency coefficients near the jumps, but the methods use one extra bit for each stencil near the discontinuities to indicate it contains a discontinuity.

Wavelet transforms based on lifting schemes have achieved large recognition in the last years [4]. One of the major reasons for this success is their flexibility: they can be used to construct linear filter banks, but also non-linear ones[5], e.g. using morphological filter [6].The lifting framework has lead to designing of adaptive and nonlinear wavelet transforms recently[7,8,9,10,11,12]. The lifting scheme consists of 3 main steps: Split, Prediction and Update. In [7, 8], an adaptive prediction step, where the adaptive switching between short and long filters based on the local edges of the input signal has been considered.

In this case, the update lifting step, which is fixed, precedes the adaptive prediction step, so that the preserving of the running average of the input signal is not affected by the adaptive prediction. In [9, 10], an adaptive update lifting scheme followed by a fixed prediction has been developed. The main objective of this method is to active adaptive smoothing in the low pass signal. However, the wavelet coefficients, i.e. the high pass subbands are affected by the adaptive update process. In [9,10], the perfect reconstruction condition for the filter coefficients was presented in the algorithm, but the method for determining the filter coefficient was not proposed. The optimal filter design method for the adaptive update wavelet transform is proposed by the authors. The optimal filter coefficients can be acquired based on the Minimum Mean Square Error Criteria (MMSE) in the algorithm.

In both above cases, either the adaptive update process or the adaptive prediction process has been adopted in the adaptive wavelet transform frameworks based on lifting schemes. Based on the adaptive lifting scheme with perfect reconstruction presented by G. Piella and the author's previous research[9,13] , this paper proposed the improved optimal adaptive wavelet transform (i.e. optimal adaptive update process and adaptive prediction process) without using extra additional information, which can achieve the better linear approximation for the piecewise continuous signals.

2. Optimal Adaptive Wavelet Transforms

In general, lifting splits a signal into two sub samples, followed by at least two lifting steps, Prediction and Update. A general lifting scheme may comprise any sequence of basic lifting steps being alternatively of prediction and update type. For the adaptive wavelet transform based on lifting scheme, the wavelet transform framework (Figure 1) by first updating and then predicting has been presented in [7,8], so the update-then-predict lifting scheme has been adopted in this paper. Considering the previous researches of the adaptive wavelet transforms, the optimal adaptive wavelet transform (i.e. adaptive update process and adaptive prediction process) based on the lifting scheme is presented.

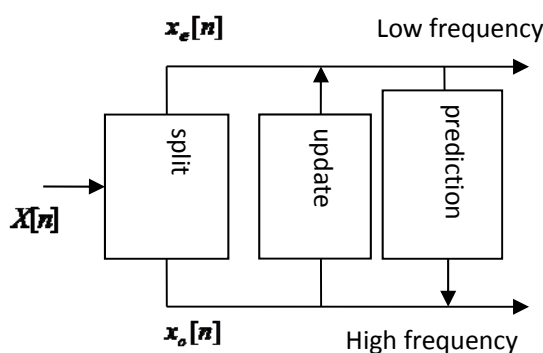

Figure 1. Update-then-prediction scheme

2.1 Adaptive update

In [9,10], an adaptive wavelet transform framework had been provided for building perfect reconstruction filter banks, which did not require any additional bookkeeping to enable inversion. In this approach, a binary map is constructed based on the gradient information and the update operator is selected according to this map. Considering the better features of this approach, the update operator presented by G. Piella has been adopted in the update process of the double adaptive wavelet transform proposed by this paper. The concrete algorithms in [9,10] has been introduced as follows:

Firstly, define the gradient vector at location n as $(v(n),w(n))=(x(n)-y(n-1),y(n)-x(n))$, In Fig.2, D is the decision set according to the value of x and y. $D(x,y)(n)=d(s(n))$, where $s(n)=|v(n)|+|w(n)|$.

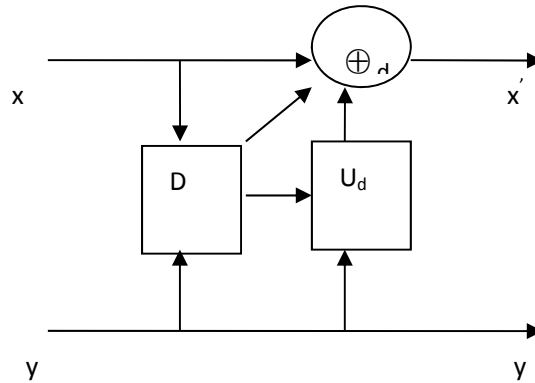

Figure 2. Adaptive update scheme

For every possible outcome $d \in D$ of the decision map, we have a different update operator U_d and addition $\oplus d$. Thus, the analysis step of our adaptive update lifting scheme looks as follows:

$$x'(n) = x(n) \oplus_d U_{d_n}(y)(n) \tag{1}$$

Where $d_n = D(x, y)(n)$ is the decision at location n.

We denote the subtraction which inverts $\oplus d$ by $\ominus d$. At synthesis we can invert (1) by

$$x(n) = x'(n) \ominus_d U_{d_n}(y)(n) \tag{2}$$

We assume that the update operator U_d is a 2-tap filter and that $\oplus d$ is the standard addition followed by some scale factor. Now, the analysis step in (1) is of the form

$$x'(n) = \alpha_{d_n} x(n) + \beta_{d_n} y(n-1) + \gamma_{d_n} y(n) \tag{3}$$

And the synthesis step (presumed that d_n is known and $\alpha_d \neq 0$) is given by

$$x(n) = 1/\alpha_{d_n} (x'(n) - \beta_{d_n} y(n-1) - \gamma_{d_n} y(n)) \tag{4}$$

Where $\alpha_{d_n}, \beta_{d_n}, \gamma_{d_n}$ are the lifting coefficients of the wavelet transforms. In order to have perfect reconstruction it is necessary that $\alpha_d + \beta_d + \gamma_d$ is constant for all $d \in D$. Based on a simple threshold criterion, to be precise, we assume that $D = \{0,1\}$ and that the function d in $D(x,y)(n)=d(s(n))$ has the form

$$d(s) = \begin{cases} 1 & \text{if } s > T \\ 0 & \text{if } s \leq T \end{cases} \tag{4}$$

Where T is the gradient threshold. We have $d'(s') = d(s)$ with $T = T'$ if and only if $0 \leq \beta_0, \gamma_0 \leq 1$ and either $\beta_1, \gamma_1 \leq 0$ or $\beta_1, \gamma_1 \geq 1$.

If the above conditions hold, then the reconstruction algorithm consists of the following steps:

- (1) Compute $s' = |x' - y| + |z - x'|$
- (2) Let $d = [s' > T]$ and put $\gamma = \gamma_d$ and $\beta = \beta_d$
- (3) Compute x from $x = \frac{x' - \beta y - \gamma z}{1 - \beta - \gamma}$

Where (x,y,z) expresses $x(n),y(n-1),y(n)$. The previous reconstruction algorithm based on the adaptive update process can be founded in [9,10].

The perfect reconstruction condition for the filter coefficients is presented in [9,10]. But the method for determining the filter coefficient was not proposed in [9,10]. For most of the signal, the smooth region is the main part of the signal. So the optimal wavelet transform filter for the smooth region was researched, and the optimal filter coefficients can be acquired based on the Minimum Mean Square Error Criteria (MMSE). The 2-level lifting wavelet transform was illustrated in Fig.3. In this lifting scheme, the mean filter was used in the prediction process. The update wavelet filter coefficients are (a_0, a_1, a_2) , and then updated data are given by

$$X'_{N-1} = a_0 X_{N-2} + a_1 X_{N-1} + a_2 X_N \quad (5)$$

$$X'_{N+1} = a_0 X_N + a_1 X_{N+1} + a_2 X_{N+2} \quad (6)$$

Put $X'_N = (X'_{N-1} + X'_{N+1})/2$, $e_N = X_N - X'_N$, then

$$X'_N = \frac{a_0(X_N + X_{N-2}) + a_1(X_{N-1} + X_{N+1}) + a_2(X_N + X_{N+2})}{2} \quad (7)$$

If μ is the mean value, where $\sum_i a_i = 1$, we can rewrite (7) as follow

$$\begin{aligned} X'_N - \mu &= \frac{a_0(X_N + X_{N-2}) + a_1(X_{N-1} + X_{N+1}) + a_2(X_N + X_{N+2})}{2} - \mu \\ &= \frac{a_0(X_N + X_{N-2}) + a_1(X_{N-1} + X_{N+1}) + a_2(X_N + X_{N+2})}{2} - \sum_{i=0}^2 a_i * \mu \\ &= \frac{a_0(X_N + X_{N-2}) + a_1(X_{N-1} + X_{N+1}) + a_2(X_N + X_{N+2}) - \sum_{i=0}^2 2a_i * \mu}{2} \\ &= \frac{a_0(X_N + X_{N-2}) + a_1(X_{N-1} + X_{N+1}) + a_2(X_N + X_{N+2}) - 2(a_0 + a_1 + a_2)\mu}{2} \\ &= \frac{a_0(X_N - \mu + X_{N-2} - \mu) + a_1(X_{N-1} - \mu + X_{N+1} - \mu) + a_2(X_N - \mu + X_{N+2} - \mu)}{2} \end{aligned} \quad (8)$$

Put $\tilde{X}'_i = X_i - \mu$, then

$$\tilde{X}'_N = \frac{a_0(\tilde{X}'_N + \tilde{X}'_{N-2}) + a_1(\tilde{X}'_{N-1} + \tilde{X}'_{N+1}) + a_2(\tilde{X}'_N + \tilde{X}'_{N+2})}{2} \quad (9)$$

Let us simplify the equation (9) through Omitting the symbol \sim above the X_i . The equation (9) can be given by

$$X'_N = \frac{a_0(X_N + X_{N-2}) + a_1(X_{N-1} + X_{N+1}) + a_2(X_N + X_{N+2})}{2} \quad (10)$$

X'_N Mean error (that is the Variance) is $E\{(X_N - X'_N)^2\}$. Where $E\{\bullet\}$ is the mathematical expectation. In order to attain the value of the filter coefficients, $E\{(X_N - X'_N)^2\}$ must be the minimum. The optimal wavelet filter coefficients (a_0, a_1, a_2) can be acquired by using the partial differential equations (PDE) for $E\{(X_N - X'_N)^2\}$. For wavelet filter coefficient a_0 , the partial differential equation is as below.

$$\begin{aligned}
 \frac{\partial E\{(X_N - X'_N)^2\}}{\partial a_0} &= \frac{\partial}{\partial a_0} E\left\{\left[X_N - \frac{a_0(X_N + X_{N-2}) + a_1(X_{N-1} + X_{N+1}) + a_2(X_N + X_{N+2})}{2}\right]^2\right\} \\
 &= -2E\left\{\left[X_N - \frac{a_0(X_N + X_{N-2}) + a_1(X_{N-1} + X_{N+1}) + a_2(X_N + X_{N+2})}{2}\right] * \frac{(X_N + X_{N-2})}{2}\right\} \\
 &= -2E\left\{\frac{\frac{X_N * X_N}{2} + \frac{X_N * X_{N-2}}{2} - \frac{a_0(X_N * X_N + 2X_N * X_{N-2} + X_{N-2} * X_{N-2})}{4}}{4} - \frac{a_1(X_{N-1} * X_N + X_{N-1} * X_{N-2} + X_{N+1} * X_N + X_{N+1} * X_{N-2})}{4} - \frac{a_2(X_N * X_N + X_N * X_{N-2} + X_{N+2} * X_N + X_{N+2} * X_{N-2})}{4}\right\} = 0
 \end{aligned} \tag{11}$$

The covariance for the signal X_i has the form

$$R_{ij} = E\{X_i * X_j\} \quad i = 1, 2, 3, \dots, N-1$$

Due to $E(X_N * X_N) = R(0)$, $E(X_N * X_{N-2}) = R(2)$, $E(X_{N-2} * X_{N-2}) = R(0)$, $E(X_{N-1} * X_N) = R(-1)$, $E(X_{N-1} * X_{N-2}) = R(1)$, $E(X_{N+1} * X_N) = R(1)$, $E(X_{N+1} * X_{N-2}) = R(3)$, $E(X_{N+2} * X_N) = R(2)$, $E(X_{N+2} * X_{N-2}) = R(4)$. Where $R(-1) \approx R(1)$, $R(-2) \approx R(2)$, the partial differential equation for a_0 is as below.

$$\begin{aligned}
 [R(0) + R(2)] * a_0 + \left[\frac{R(3)}{2} + \frac{3}{2}R(1)\right] * a_1 + \left[\frac{R(0)}{2} + R(2) + \frac{R(4)}{2}\right] * a_2 \\
 = R(0) + R(2)
 \end{aligned} \tag{12}$$

For wavelet filter coefficient a_1 , the partial differential equation is as below.

$$\begin{aligned}
 \frac{\partial E\{(X_N - X'_N)^2\}}{\partial a_1} &= \frac{\partial}{\partial a_1} E\left\{\left[X_N - \frac{a_0(X_N + X_{N-2}) + a_1(X_{N-1} + X_{N+1}) + a_2(X_N + X_{N+2})}{2}\right]^2\right\} \\
 &= -2E\left\{\left[X_N - \frac{a_0(X_N + X_{N-2}) + a_1(X_{N-1} + X_{N+1}) + a_2(X_N + X_{N+2})}{2}\right] * \frac{(X_{N-1} + X_{N+1})}{2}\right\} \\
 &= -2E\left\{\frac{\frac{X_N * X_{N-1}}{2} + \frac{X_N * X_{N+1}}{2} - \frac{a_0(X_{N-2} * X_{N-1} + X_{N-2} * X_{N+1} + X_N * X_{N-1} + X_N * X_{N+1})}{4}}{4} - \frac{a_1(X_{N-1} * X_{N-1} + X_{N-1} * X_{N+1} + X_{N+1} * X_{N-1} + X_{N+1} * X_{N+1})}{4} - \frac{a_2(X_N * X_{N-1} + X_N * X_{N+1} + X_{N+2} * X_{N-1} + X_{N+2} * X_{N+1})}{4}\right\} = 0
 \end{aligned} \tag{13}$$

Due to $E(X_N * X_{N-1}) = R(1)$, $E(X_N * X_{N+1}) = R(-1)$, $E(X_{N-2} * X_{N-1}) = R(-1)$, $E(X_{N-2} * X_{N+1}) = R(-3)$, $E(X_N * X_{N-1}) = R(1)$, $E(X_N * X_{N+1}) = R(-1)$, $E(X_{N-1} * X_{N-1}) = R(0)$, $E(X_{N-1} * X_{N+1}) = R(-2)$, $E(X_{N+1} * X_{N-1}) = R(2)$, $E(X_{N+2} * X_{N-1}) = R(3)$, $E(X_{N+2} * X_{N+1}) = R(1)$.

Where $R(-1) \approx R(1)$, $R(-2) \approx R(2)$, $R(-3) \approx R(3)$, the partial differential equation for a_1 is as below.

$$\frac{[3R(1) + R(3)]}{2} * a_0 + [R(0) + R(2)] * a_1 + \frac{[3R(1) + R(3)]}{2} * a_3 = 2R(1) \tag{14}$$

For wavelet filter coefficient a_2 , the partial differential equation is as below.

$$\begin{aligned}
 \frac{\partial E\{X_N - X'_N\}^2}{\partial a_2} &= \frac{\partial}{\partial a_2} E\left\{ \left[X_N - \frac{a_0(X_N + X_{N-2}) + a_1(X_{N-1} + X_{N+1}) + a_2(X_N + X_{N+2})}{2} \right]^2 \right\} \\
 &= -2E\left\{ \left[X_N - \frac{a_0(X_N + X_{N-2}) + a_1(X_{N-1} + X_{N+1}) + a_2(X_N + X_{N+2})}{2} \right] * \frac{(X_N + X_{N+2})}{2} \right\} \\
 &= -2E\left\{ \frac{\frac{X_N * X_N}{2} + \frac{X_N * X_{N+2}}{2} - \frac{a_0(X_{N-2} * X_N + X_{N-2} * X_{N+2} + X_N * X_N + X_N * X_{N+2})}{4}}{4} - \frac{a_1(X_{N-1} * X_N + X_{N-1} * X_{N+2} + X_{N+1} * X_N + X_{N+1} * X_{N+2})}{4} - \frac{a_2(X_N * X_N + X_N * X_{N+2} + X_{N+2} * X_N + X_{N+2} * X_{N+2})}{4} \right\} = 0
 \end{aligned}
 \tag{15}$$

Due to $E(X_N * X_N) = E(X_{N+2} * X_{N+2}) = R(0)$, $E(X_N * X_{N+2}) = E(X_{N-2} * X_N) = R(-2)$, $E(X_{N+2} * X_N) = R(2)$, $E(X_{N-2} * X_{N+2}) = R(-4)$, $E(X_{N-1} * X_N) = R(-1)$, $E(X_{N-1} * X_{N+2}) = R(-3)$, $E(X_{N+1} * X_N) = R(1)$, $E(X_{N+1} * X_{N+2}) = R(-1)$, $E(X_N * X_{N+2}) = R(-2)$. Where $R(-1) \approx R(1)$, $R(-2) \approx R(2)$, $R(-3) \approx R(3)$, $R(-4) \approx R(4)$, the partial differential equation for a_2 is as below.

$$\frac{[2R(2) + R(0) + R(4)]}{2} * a_0 + \frac{[3R(1) + R(3)]}{2} * a_1 + [R(0) + R(2)] * a_2 = R(0) + R(2) \tag{16}$$

Equation (10), (12) and (16) are the equation group, In order to acquire the solution of equations, that is the filter coefficient (a_0, a_1, a_2) , the signal covariance R_{ij} must be known. Using the signal sample value, R_{ij} can be obtained, so the optimal filter coefficients can also be acquired.

So far, the design method for the optimal wavelet filter had been carefully illustrated in this section. In the next section, the experiment results will be shown.

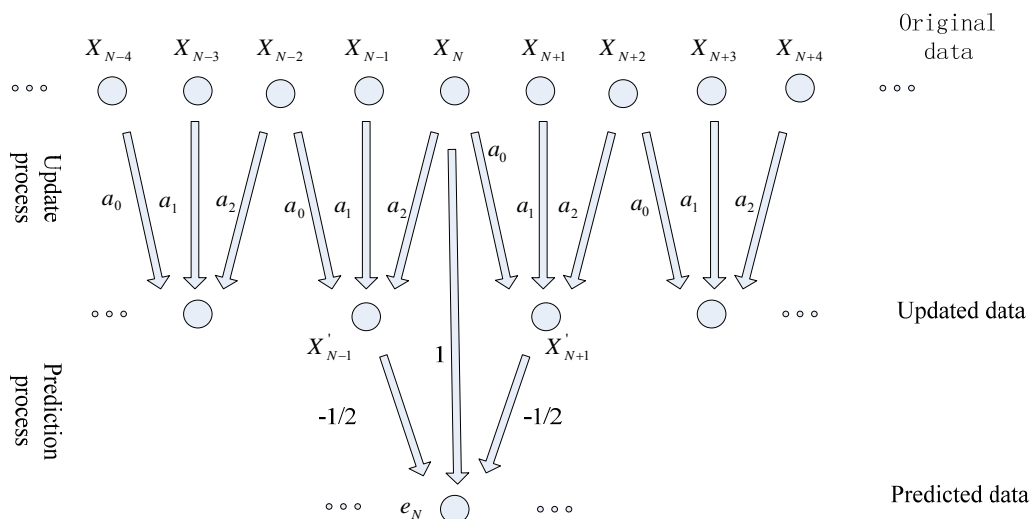

Figure 3. 2-level lifting wavelets transform

2.2 Adaptive prediction

The Because of the update-then-prediction lifting scheme adopted in this paper, the update process cannot be affected by the prediction process using the adaptive transform scheme. (This paper adopts the adaptive scheme proposed in [9], where these operations depend on the properties of the input signal.). In order to implement adaptive prediction algorithm, there are two crucial points in designing wavelet transform scheme: The first is to detect the jumps in the signal. In order to avoid generating extra edge

information, we use the updated data for detecting jumps. This scheme is reversible. When the data has a jump, the position of this jump is preserved after updating. The second is how to use one-sided data near jumps to avoid oscillations. The jumps generate large high frequency wavelet coefficients if we adopt the same wavelet filter as the smooth region. So the jumps can be predicted by the left or the right data of the jumps in this paper. Assuming that β_{2i+1} is the jump (predicted point), α_{2i} is its left side data (updated data) and α_{2i+2} is its right side data (updated data), the three-point relationship can be summed up the four modes in figure 4. The four modes can be introduced carefully as follows:

Model1: If $\alpha_{2i+2} > \alpha_{2i}, \beta_{2i+1} < (\alpha_{2i+2} + \alpha_{2i})/2$, the relative of $\alpha_{2i}, \beta_{2i+1}, \alpha_{2i+2}$ can be summed up Mode 1 scheme. For this scheme, β'_{2i+1} is the jump of the prediction data, and α'_{2i+2} is the jump of the updated data. For the LeGall 5/3, the lifting scheme can be shown in figure 5, so update-prediction process as follow:

$$\text{Update: } \alpha'_{2i} = \alpha_{2i} + (\beta_{2i-1} + \beta_{2i+1})/4$$

$$\text{Prediction: } \beta'_{2i+1} = \beta_{2i+1} - (\alpha'_{2i} + \alpha'_{2i+2})/2$$

If e_{2i} denotes the mean linear error of the updated data. The following equations can be acquired.

$$|e_{2i}| = |\alpha'_{2i} - (\alpha'_{2i-2} + \alpha'_{2i+2})/2| \tag{17}$$

$$|e_{2i+2}| = |\alpha'_{2i+2} - (\alpha'_{2i} + \alpha'_{2i+4})/2| \tag{18}$$

For the mode 1, α'_{2i} can be updated in the smooth fields, so $\alpha'_{2i} \approx \alpha'_{2i-2}$.for the equation (17) can be written as follows

$$|e_{2i}| = |(\alpha'_{2i} - \alpha'_{2i+2})/2| \tag{19}$$

Through decomposing of the equation (18), equation (20) can be acquired.

$$|e_{2i+2}| = |(\alpha'_{2i+2} - \alpha'_{2i})/2 + (\alpha'_{2i+2} - \alpha'_{2i+4})/2| \tag{20}$$

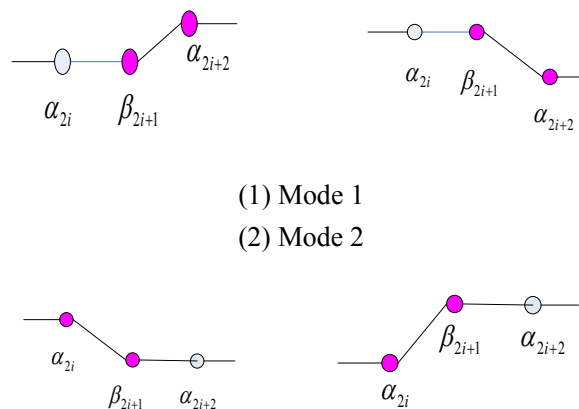

Figure 4. Four modes

In the update process, α'_{2i+2} can be updated by the value of the β_{2i+1} , the update process as follows:

$$\alpha'_{2i+2} = \alpha_{2i+2} + (\beta_{2i+1} + \beta_{2i+3})/4 \tag{21}$$

$$\alpha'_{2i+4} = \alpha_{2i+4} + (\beta_{2i+3} + \beta_{2i+5})/4 \tag{22}$$

For the mode 1, α_{2i+2} and α_{2i+4} locate the same smooth fields, that is $\alpha_{2i+2} \approx \alpha_{2i+4} \cdot \beta_{2i+3}$ and β_{2i+3} and β_{2i+5} locate the same smooth fields, that is $\beta_{2i+3} \approx \beta_{2i+5}$. However, β_{2i+1} and β_{2i+3} locate at two sides of the jump, and $\beta_{2i+1} < \beta_{2i+3}$, according to equation (21) and(22), equation (23) can be acquired.

$$\alpha'_{2i+2} < \alpha'_{2i+4} \tag{23}$$

According to equation(19),(20) and (23), $|e_{2i}| > |e_{2i+2}|$ and $e_{2i} * e_{2i+2} < 0$ can be known, we can get the prediction equations for this scheme

$$\beta'_{2i+1} = \beta_{2i+1} - \alpha_{2i} \tag{24}$$

Where β'_{2i+1} is the predicted high frequency coefficient.

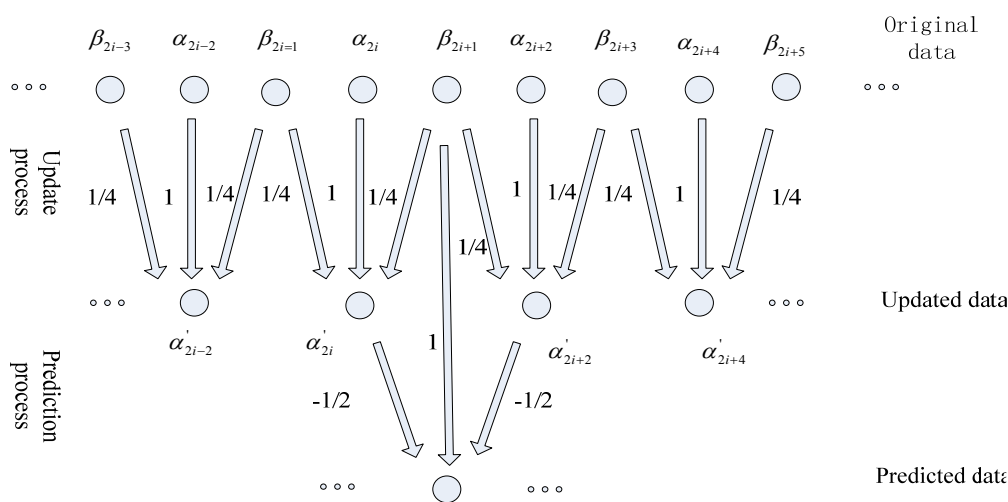

Figure 5. 2-level lifting wavelet transform

Mode 2: If $\alpha_{2i+2} < \alpha_{2i}, \beta_{2i+1} > (\alpha_{2i+2} + \alpha_{2i})/2$, the relative of $\alpha_{2i}, \beta_{2i+1}, \alpha_{2i+2}$ can be summed up Mode 2 scheme. For this scheme, β_{2i+1} is the jump of the prediction data, and α_{2i+2} is the jump of the updated data. In the update process, α_{2i+2} can be affected by the value of β_{2i+1} . When we calculate the linear prediction error of the updated data, the left prediction errors of α_{2i+2} (that is α_{2i+4} point) are usually larger than that of α_{2i} .

Based on deduction method as mode 1, we can get the prediction equations for this scheme

$$\beta'_{2i+1} = \beta_{2i+1} - \alpha_{2i} \tag{25}$$

Where β'_{2i+1} is the predicted high frequency coefficient.

Mode 3: If $\alpha_{2i+2} < \alpha_{2i}, \beta_{2i+1} < (\alpha_{2i+2} + \alpha_{2i})/2$, the relative of $\alpha_{2i}, \beta_{2i+1}, \alpha_{2i+2}$ can be summed up Mode 3 scheme. For this scheme, β_{2i+1} is the jump of the prediction data, and α_{2i+2} is the jump of the updated data. In the update process, α_{2i} can be affected by the value of β_{2i+1} . When we calculate the linear prediction error of the updated data, the right prediction errors of α_{2i} (that is α_{2i-2} point) are usually larger than that of α_{2i+2} . Based on deduction method as mode 1, we can get the prediction equations for this scheme

$$\beta'_{2i+1} = \beta_{2i+1} - \alpha_{2i+2} \tag{26}$$

Where β'_{2i+1} is the predicted high frequency coefficient.

Mode 4: If $\alpha_{2i+2} > \alpha_{2i}, \beta_{2i+1} > (\alpha_{2i+2} + \alpha_{2i})/2$, the relative of $\alpha_{2i}, \beta_{2i+1}, \alpha_{2i+2}$ can be summed up Mode 4 scheme. For this scheme, β_{2i+1} is the jump of the prediction data, and α_{2i+2} is the jump of the updated data. In the update process, α_{2i} can be affected by the value of β_{2i+1} . When we calculate the linear prediction error of the updated data, the right prediction errors of α_{2i} (that is α_{2i-2} point) are usually larger than that of α_{2i+2} . Based on deduction method as mode 1, we can get the prediction equations for this scheme

$$\beta'_{2i+1} = \beta_{2i+1} - \alpha_{2i+2} \tag{27}$$

Where β'_{2i+1} is the predicted high frequency coefficient.

According to the previous analysis, the adaptive prediction algorithm consists of the following steps:
For each index i:

- (1) Calculate the linear error e_{2i} sequence of the update data α_{2i} sequence from

$$e_{2i} = \alpha_{2i} - (\alpha_{2i-2} + \alpha_{2i+2}) / 2$$

- (2) For the e_{2i} sequence, the multiplying value of the two adjacent numbers is calculated, that is

$$\text{the value of } e_{2i} \times e_{2i+2} .$$

If this value is negative, β_{2i+1} are the jumps,

Then the next step will be performed.

Else

$$\beta'_{2i+1} = \beta_{2i+1} - (\alpha_{2i} + \alpha_{2i+2}) / 2 , \text{ we get the high frequency coefficient sequence.}$$

- (3) If the α_{2i} is the jump of the updated data, the value of $|e_{2i-2}|$ is larger. Otherwise, the value of $|e_{2i+4}|$ is larger. Comparing with the value between $|e_{2i-2}|$ and $|e_{2i+4}|$, the prediction algorithm using the left side data or the right side data of the jump can be determined.

If $|e_{2i-2}| > |e_{2i+4}|$ then

$$\beta'_{2i+1} = \beta_{2i+1} - \alpha_{2i}$$

Else If $|e_{2i-2}| > |e_{2i+4}|$ then

$$\beta'_{2i+1} = \beta_{2i+1} - \alpha_{2i+2}$$

Else

$$\beta'_{2i+1} = \beta_{2i+1} - (\alpha_{2i} + \alpha_{2i+2}) / 2$$

Through the previous discussion, we know that the adaptive prediction algorithm can be reconstructed without using extra additional information. The inverse transform algorithm is the inverse process of the forward wavelet transform.

3. Simulation Results

Next, we consider a piecewise smooth function defined by

$$f(x) = \begin{cases} 0 & 0 \leq x < 0.2 \\ -50x - 5 & 0.2 \leq x < 0.4 \\ 10 \sin(4\pi x + 0.8\pi) - 1 & 0.4 \leq x < 1.1 \\ 5e^{2x} - 100 & 1.1 \leq x < 1.6 \\ 0 & 1.6 \leq x \leq 2.0 \end{cases}$$

Figure 6 shows the function $f(x)$. In order to study on the performance of the optimal adaptive wavelet transform, the five different wavelet transform scheme are listed as follows:

Non-adaptive wavelet transform: Update-then-Prediction scheme. The coefficient $(1/4, 1/2, 1/4)$ for the wavelet filter is chosen in the update process, and the filter is the same as that of $(5, 3)$ wavelet in the prediction process.

Adaptive update wavelet transform: Adaptive update and non-adaptive prediction scheme. We adopt the adaptive update scheme proposed in [9, 10]. The filter coefficients are $(a_0 = 1/4, a_1 = 1/2, a_2 = 1/4)$ for smooth region, and the filter coefficients are $(a_0 = 0, a_1 = 1, a_2 = 0)$ for the jumps. The filter is the same as that of $(5, 3)$ wavelet in the prediction process.

Adaptive prediction wavelet transform: update and adaptive prediction scheme. The filter coefficients are $(a_0 = 1/4, a_1 = 1/2, a_2 = 1/4)$ in the update process. We adopt the adaptive prediction algorithms proposed by this paper.

Adaptive wavelet transform: Adaptive update and adaptive prediction scheme. We adopt the adaptive update scheme proposed in [9, 10]. The filter coefficients are $(a_0 = 1/4, a_1 = 1/2, a_2 = 1/4)$ for smooth region, and the filter coefficients are $(a_0 = 0, a_1 = 1, a_2 = 0)$ for the jumps. The adaptive prediction algorithms proposed by this paper are chosen.

Optimal adaptive wavelet transform: Optimal adaptive update and adaptive prediction scheme. we adopt the optimal adaptive update scheme proposed by this paper. Through calculating the covariance R_{ij} of the tested signal, the filter coefficients $(a_0 = 0.4990, a_1 = 0.3775, a_2 = 0.1241)$ are acquired. Considering the perfect reconstruction condition for the filter in [9,10], we selected $(a_0 = 5/10, a_1 = 4/10, a_2 = 1/10)$ as the optimal coefficients of wavelet filter for smooth region, and the filter coefficients are $(a_0 = 0, a_1 = 1, a_2 = 0)$ for the jumps. The adaptive prediction algorithms proposed by this paper are chosen.

Using the non-adaptive wavelet transform scheme, one level wavelet decomposition for the $f(x)$ is shown in fig.7. The left part corresponds to the low frequency coefficients and the right part the high

frequency coefficients. Because we get the similar low frequency coefficients using the wavelet transform scheme listed in this chapter, the transformed high frequency coefficients will be researched. In fig.8, 9,10 and 11, we present the adaptive prediction, adaptive update ,adaptive wavelet and optimal adaptive wavelet transform 1-level decomposition high frequency coefficients respectively. For the adaptive prediction or adaptive update wavelet transform scheme, we notice that there are some large high frequency coefficients near the discontinuities. On the other hand, no large high frequency coefficients are present in the optimal adaptive wavelet transform. This illustrates that the optimal adaptive wavelet coefficients have better distribution than other wavelet transform listed in this paper, i.e., no large coefficients in the high frequencies and the energy is concentrated in the low frequency end. According to the signal energy calculation formula: $SignalEnergy = \sum_{i=1}^n X_i * X_i$, where X_i is the value of the signal sequence, the 1-level decomposition high coefficient energy of the different wavelet transform scheme listed in Table 1. From the table 1, the optimal adaptive wavelet transform has better energy concentration. The performances of this wavelet transform scheme meet the demand of the image compression.

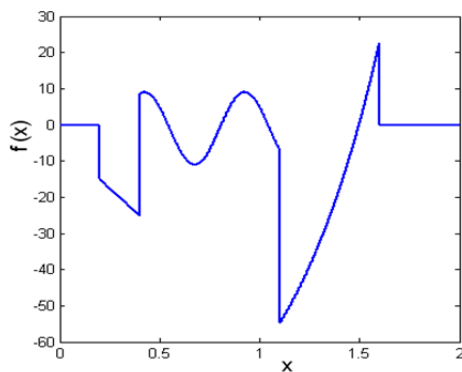

Figure 6. A piecewise smooth signal

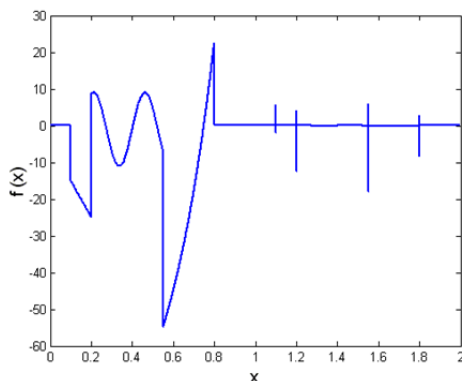

Figure 7. Non-adaptive wavelet 1-level decomposition for the piecewise smooth signal

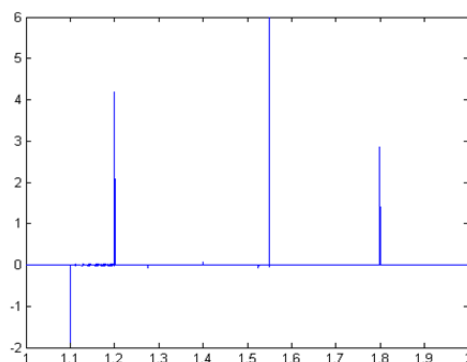

Figure 8. 1-level decomposition high frequency coefficients for the adaptive prediction wavelet transform

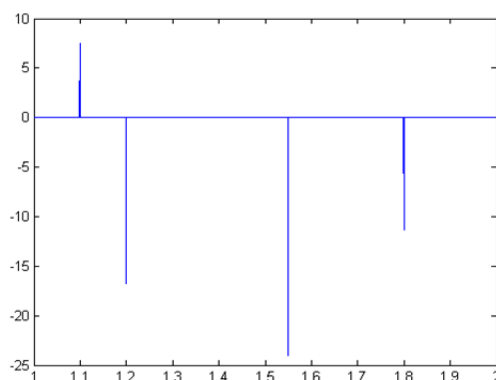

Figure 9. 1-level decomposition high frequency coefficients for the adaptive update wavelet transform

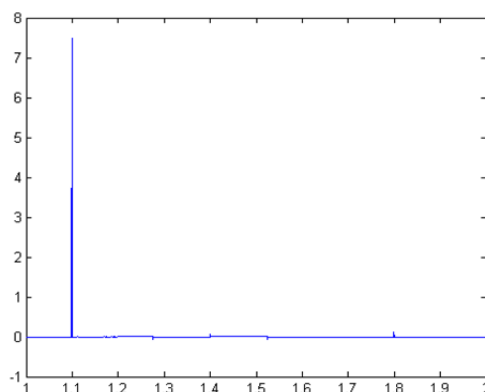

Figure 10. 1-level decomposition high frequency coefficients for the adaptive wavelet transform

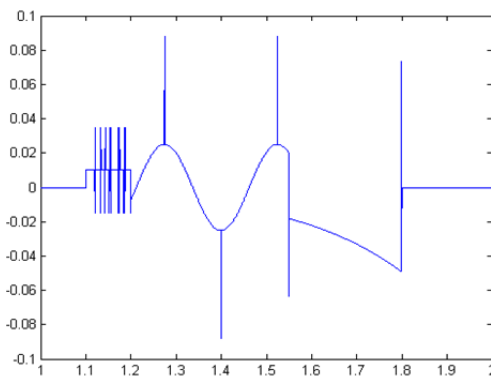

Figure 11. 1-level decomposition high frequency coefficients for the optimal adaptive wavelet transform

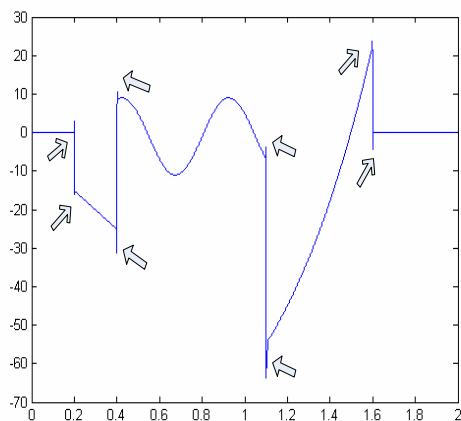

Figure 12. 1-level linear approximation for the non-adaptive wavelet transform

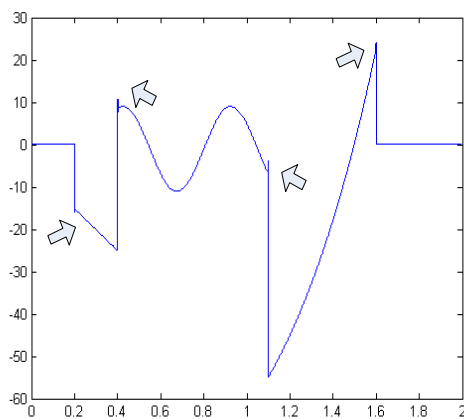

Figure 13. 1-level linear approximation for the adaptive prediction wavelet transform

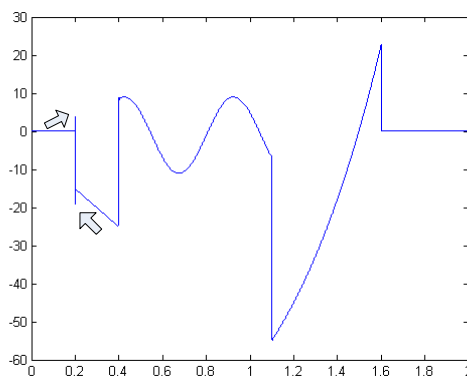

Figure 14. 1-level linear approximation for the adaptive update wavelet transform

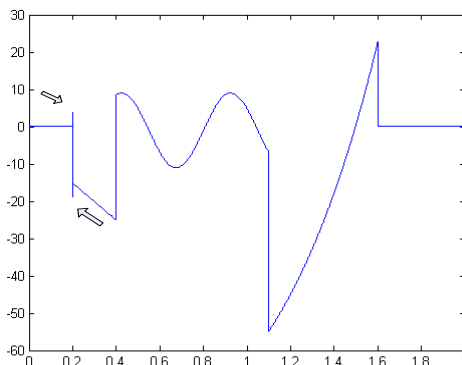

Figure 15. 1-level linear approximation for the adaptive wavelet transform

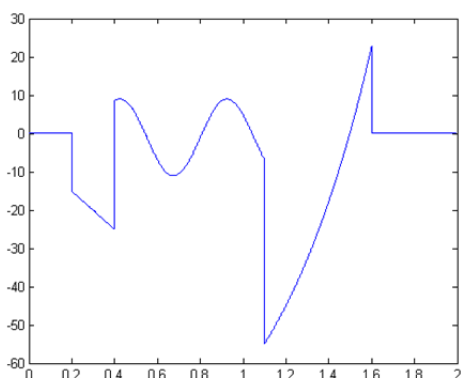

Figure 16. 1-level linear approximation for the optimal adaptive wavelet transform

Using the wavelet transform scheme listed in this chapter, the different wavelet linear approximations are shown in Figure 12、13、14、15 and 16 respectively. From the figure 12, we notice that the non-adaptive wavelet linear approximation generate the oscillations near the discontinuity (Arrow shows the location in figure). In figure 13、14 and 15, it is evident that these schemes can reduce the oscillations near the discontinuity (Arrow shows the location in figures). In figure 16, the oscillations near the discontinuity can be basically eliminated. Comparing with the original signal $f(x)$, the linear approximation has the smaller distortion. With studying on the optimal adaptive wavelet transform scheme, the simulation results demonstrate that it can eliminate the oscillations near the discontinuity, and has better linear approximation.

Table 1. The 1-level decomposition high frequency coefficients energy of the different wavelet transform scheme

Wavelet transform scheme	energy
Non-adaptive wavelet transform	651.053
Adaptive update wavelet transform	1.0413e+003
Adaptive prediction wavelet transform	65.0251
Adaptive wavelet transform	56.3078
Optimal adaptive wavelet transform	0.8065

4. Conclusions

Based on the double adaptive wavelet transform proposed in this paper, the simulation results demonstrate that it has better linear approximation of the smooth piecewise function, and can also reduce the high frequency coefficients. At the same time, comparing with the algorithms in [13], the optimal adaptive wavelet transform can be implemented without sending any side information. A wavelet based image compression algorithm usually consists of three steps, namely transform, quantization and coding. Quantization refers to truncating the real valued wavelet coefficients into a finite set of fixed values so that they can be used in coding process. In this step, the small wavelet coefficients are usually quantized to zero. Therefore, the smaller wavelet coefficients a transform generates the better compression it achieves. The double adaptive wavelet transform presented by the authors meets the demand of image compression. How to use this algorithm together with quantization and coding steps to form complete image compression algorithms will be researched in the future.

References

- [1] M. Antonini, M. Barlaud, P. Mathieu, I. Daubechies, "Image Coding Using Wavelet Transform", IEEE Trans. Image Process. Vol.1, No.2, pp. 205-220, April,1992.
- [2] R. C. Calderbank, I. Daubechies, W. Sweldens, B.-L. Yeo, "Wavelet Transforms That Map Integers To Integers", Appl. Comput. Harmon. Anal. No.3, pp.337-357,1996.
- [3] T. F. Chan and H. M. Zhou, "Adaptive ENO-wavelet Transforms For Discontinuous Functions", Technical Report 99-21, Dept. of Math, UCLA, June 1999.
- [4] W. Sweldens, "The Lifting Scheme: A Construction Of Second Generation Wavelets", SIAM J. Math. Anal., Vol.29, No.2, pp.511-546,1997.
- [5] F.J.Hampson and J.C.Pesquet, "M-band Nonlinear Subband Decompositions With Perfect Reconstruction", IEEE Transactions on Image Processing, Vol. 7, pp. 1547-1560,1998.
- [6] H. J. A. M. Heijmans, J.Goutsias, "Nonlinear Multiresoution Signal Decomposition Schemes. Part II: Morphological Wavelets", IEEE Transaction on Image Processing, Vol.9, No.11, pp.1897-1913,2000.
- [7] R. Claypoole, R. Baraniuk, and R. Nowak, "Nonlinear Wavelet Transforms For Image Coding", In Proceedings of the 31st Asilomar Conference on Signals, Systems, and Computers, Volume 1, 1997, pp.662-667.
- [8] R. Claypoole, R. Baraniuk, and R. Nowak, "Adaptive Wavelet Transforms Via Lifting", In Proceedings of the IEEE International Conference on Acoustics, Speech, and Signal Processing, Seattle, Washington, May 12-15,1998.
- [9] G.Piella, H. J. A. M. Heijmans, "Adaptive Lifting Schemes With Perfect Reconstruction", PNA-R0104, CWI, Amsterdam, February 28,2001.
- [10] H. J. A. M. Heijmans, B.Pesquet-Popescu, G.Piella, "Building Nonredundant Adaptive Wavelets By Update Lifting", PNA-R0212, CWI, Amsterdam, May 31, 2002.
- [11] G.C.K.Abhayaratne, "Spatially Adaptive Integer Lifting With No Side Information For Lossless Video Coding", Picture Coding Symposium(PCS 03), pp.495-500,2003.
- [12] Yu Wu, Guoyin Wang, Neng Nie, "Adaptive Lifting Scheme Of Wavelet Transforms For Image Compression", Proceeding of SPIE, Vol. 4391 on Wavelet Application III, pp.154-160,2001.
- [13] GAO Guang-chun, Yao Qing-dong. New method for calculating lifting coefficients of biorthogonal wavelet. Journal of Zhejiang University: Engineering Science, Vol.38, No.12, pp. 1665-1668,2004.(in Chinese)